

SM-100 Series

Scale Printer



SM-100P



SM-100H

The Preferred Choice
For Service Scale Printer

SM-100 Series
Scale Printer

Scale Printer

Model Specification

MAIN FEATURES

Model	SM-100P(Pole Type) SM-100H(Hanging Type)
Dimension(in mm)	386(W)X478(D)X480(H)(SM-100P) 350(W)X369(D)X844(H)(SM-100H)
Capacity	3/6kg : 1-2g 6/15kg : 2-5g 15/30kg : 5-10g
Memory capacity	1M(standard) 2M(option)
Number of preset keys	42 (SM-100P) 56 (SM-100H)
Display resolution	1/3,000(dual range)
Display	19segments LCD with red back-light Tare Weight display : 4digits Weight display : 5digits Unit Price display : 6digits Total Price display : 7digits
Printing	Paper Width : Max60mm(lable) 60mm(Receipt) Speed : 80mm/sec(label) 105mm/sec(receipt) Label size : Maxium 60(W)X220(L)mm
Power source	AC 100/110/117/220/230/240Volts (50/60Hz)
Operating teperature	-10°C to 40°C
Humidity	15% to 85%RH
Net weight	11.7kg (SM-100P) 11.5kg (SM-100H)

INTERFACE

Standad interface	RS-232C,Cash Drawer, Ethernet
Optional interface	WirelessRF IEEE 802.11b

SM-100P

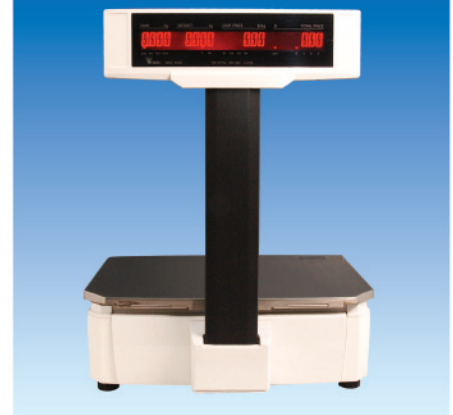

SM-100H



Dimension

SM-100P
(mm)

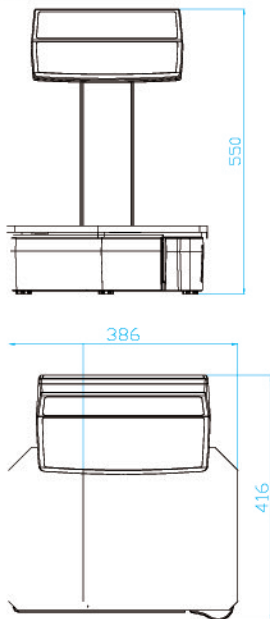

SM-100H
(mm)

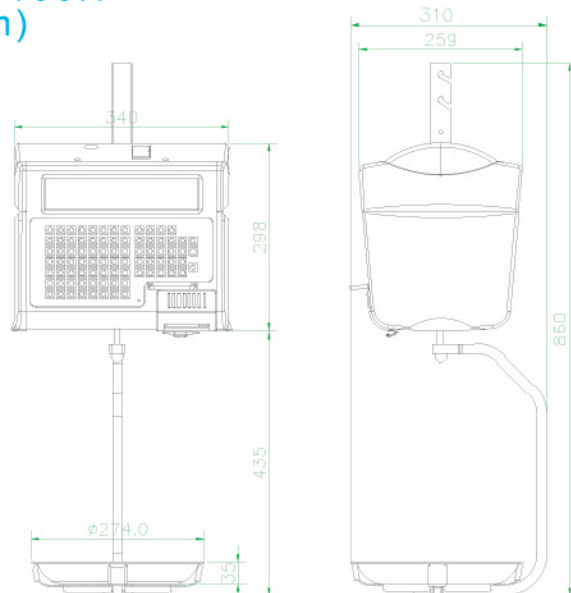

*Specifications are subject to change without notice.

TERAOKA SEIKO CO.,LTD.

13 12 KUGAHARA 5 CHOME OHTA KU,
TOKYO 146-8580 JAPAN
TEL:+81-3-3752-2131 FAX:+81-3-3752-2801